

## 注塑用机械手 TAKE-OUT ROBOT

AD-80  
AD-80s



### 标准功能 STANDARD FUNCTION

- 1-99点的位置动作  
Positioning 1-99
- 取出侧姿势控制)  
Posture control at extract side
- 不良品排出回路  
Defective product reject circuit
- 副臂单独动作  
Sub-arm individual motion
- 胶口途中开放 (去程, 返程)  
Midway runner release (Move, Revert)
- 模内开放  
Product release within mold
- 内部存储记忆 (最大30种类型)  
Internal memory (for Max 30 molds)
- 吸着确认单元 (1回路)  
Additional vacuum sensing unit (1 circuit)
- 落下测下降低速  
Slow speed descent at release side
- 横走行待机  
Delayed traverse
- 输送带启动信号  
Start signal of conveyor
- 水口落下测下降  
Runner descent at release side
- 水口侧可动取出  
Runner extraction from moving side
- 2国语言切换 (中文, 英文)  
Two language exchange (Chinese/English)

### 型式 MODEL 单位 UNIT AD-80 AD-80s

型式 MODEL	单位 UNIT	AD-80	AD-80s
电源 Power Source	V	AC 200 ~ 220 ± 10% 50/60Hz	
最大消费电力 Max Power Consumption	KW	0.45	
使用气压 Air Pressure	Mpa	0.5 ~ 0.7	
空气消费量 Air Consumption	NI/cycle	13.8	23.9
驱动方式 Drive System	---	伺服马达 / AC Servo Motor	
姿势 (气缸) Posture (Air Cylinder)	---	90°固定 / 90°Fixed	
■ 气缸推力 (气压0.49MPa时) Air Cylinder Driving Force (Air Pressure at 0.49MPa)			
最大可搬重量 Max.Load	Kg	3【含夹具重量 / Incl Chuck Weight】	
姿势力矩 Posture Torque	N · m	8.3	
■ 行程 Stroke			
主臂上下 Main-arm Vertical	mm	600/800	600/800
副臂上下 Sub-arm Vertical	mm	---	600/800
前后(主臂,副臂) Crosswise (M,S)	mm	主臂/M 300	主臂/M 300 副臂/S 150
走行 Traverse	mm	1400	
■ 本体重量 Net Weight			
本体 Main Body	Kg	208	
操作盒 Pendant	Kg	1.6	

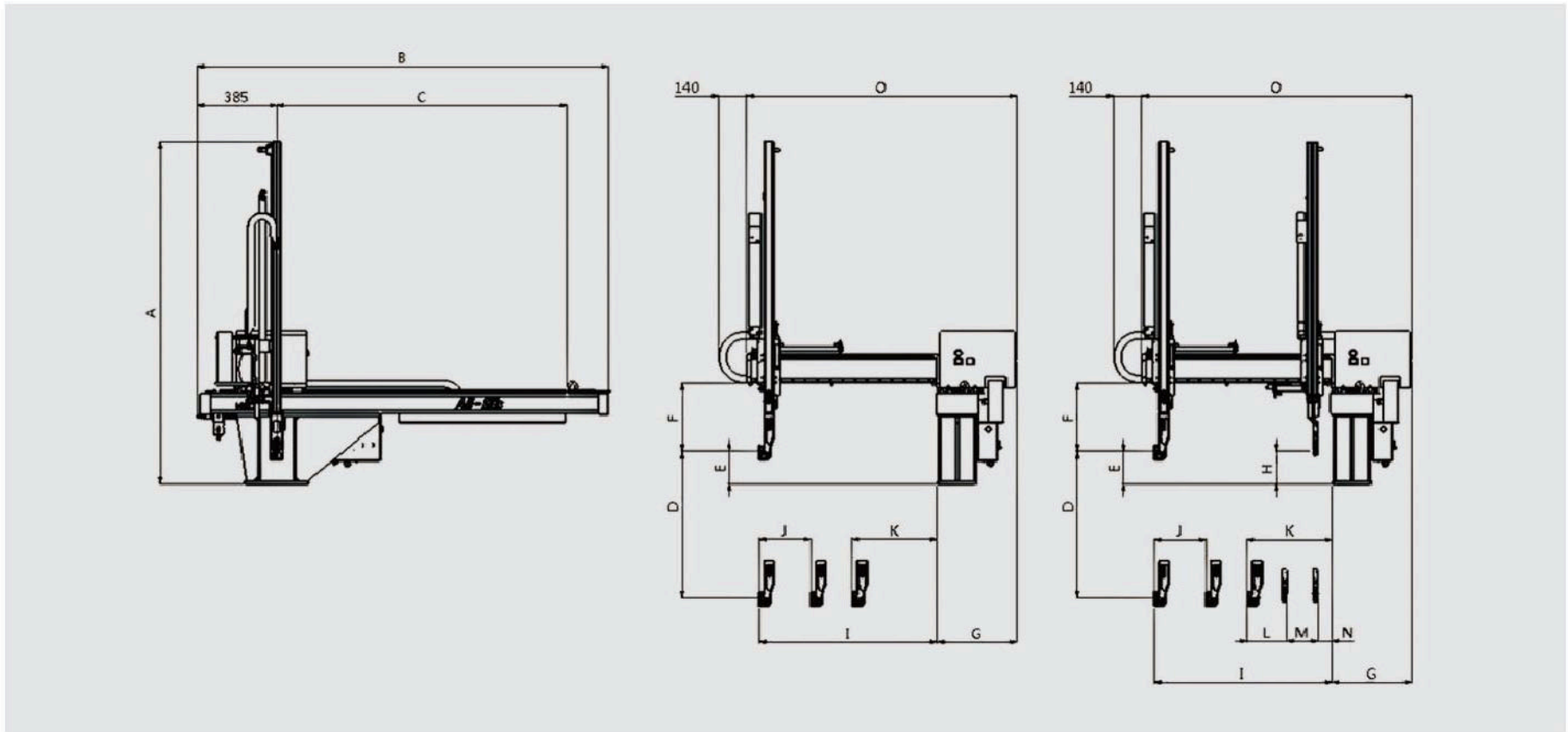

### 外形尺寸 OUTER DIMENSIONS

### AD-80 AD-80s

### 选项功能 OPTION FUNCTION

A	总高 Overall height	1440(1620)mm	
B	总长 Overall length	1970mm	
C	走行行程 Traverse stroke	1400mm	
D	主臂上下行程 Main-arm vertical stroke	600 ( 800 ) mm	
E	主臂上下待机 Main-arm vertical standby	200mm	
F	夹具安装有效空间 Bottom of crosswise to chuck mount position	325mm	
G	底座里侧面-箱体末端 Base side face-Box end	385 mm	
H	副臂上下待机 Sub-arm Vertical standby	---	230 mm
I	主臂前进最大值 Main-arm reach max	860 mm	
J	主臂前进最大行程 Main-arm crosswise stroke max	300 mm	300 mm
K	主臂前后待机最小值 Main-arm crosswise standby min	140 mm	250 mm
L	主副臂接近最小值 Main/Sub-arm proximity min	---	175 mm
M	副臂前进最大行程 Sub-arm crosswise stroke max	---	150 mm
N	副臂前后待机最小值 Sub-arm crosswise standby min	---	70 mm
O	前后臂末端-箱体末端 Crosswise arm end-Box end	1300 mm	

- ◆ 夹具内剪刀回路  
Air nipper in chuck circuit
- ◆ NT动作剪切装置  
NT gate cut
- ◆ 吸着确认2回路  
Additional vacuum sensing unit ( 2 circuits )
- ◆ 滑移取出  
Under-cut extraction
- ◆ 固定可动切换  
Extraction from fixed side
- ◆ 制品确认  
Product confirmation

- 当尺寸D是600mm时，尺寸A为1440mm
- when dimension D is 600mm , A is 1440mm

- 当尺寸D是800mm时，尺寸A为1620mm
- when dimension D is 800mm , A is 1620mm