

注塑用机械手 TAKE-OUT ROBOT

L-650[V]

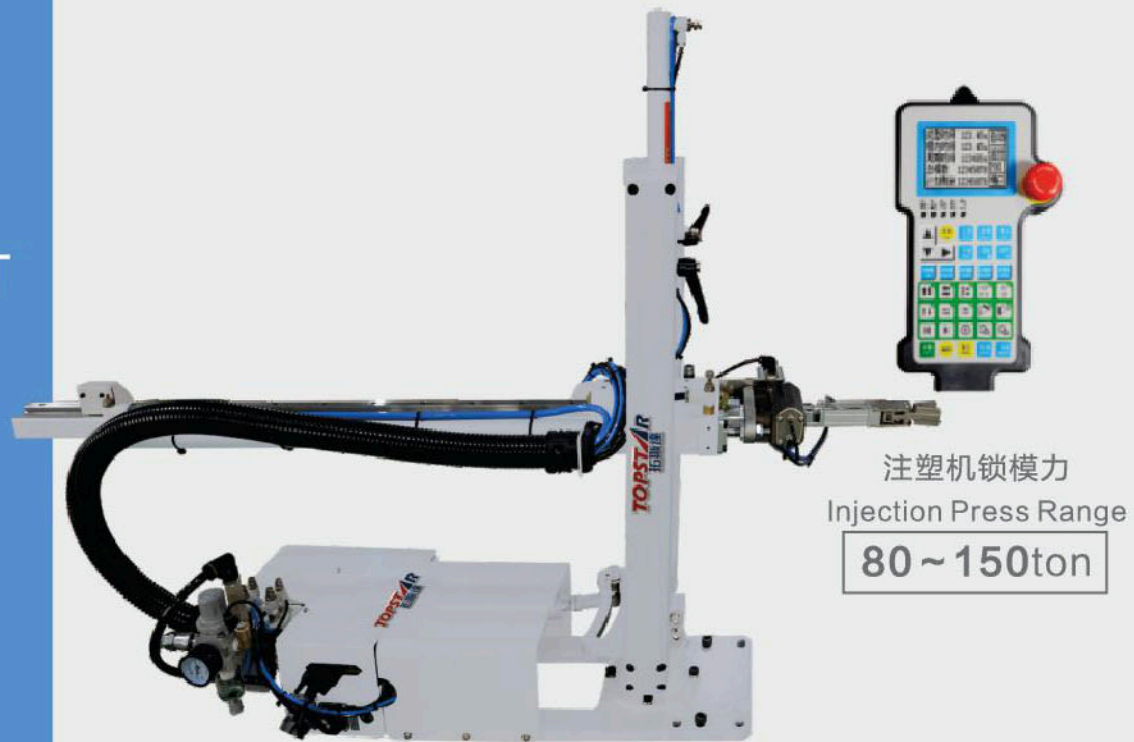

注塑机锁模力
Injection Press Range
80 ~ 150ton

特长

- 上下待机位置手柄调整功能。
旋转手柄可调节进入模具上下方向的位置
- 回转角度调整功能。
简单机械调整可变更回转方向及回转角度
- 夹具部反转功能。
夹具部反转可使浇口释放平顺完成
- 固定侧 · 可动侧切换。
固定侧可动侧对应切换

Features

- Vertical standby position adjustment function with handle.
Adjustment of top and bottom direction of entry position to mold is possible by turning the handle.
- Rotation angle adjustment function.
Simple machine adjustment makes it possible to change the direction of rotation and to adjust the rotation angle
- Chuck part reversal function.
Sprue runner release is performed smoothly by chuck twist
- Extraction from fixed & moving side mold.
Sprue runner of fixed part mold can be extracted

型式 MODEL 单位 UNIT L-650[V]

电源 Power Source	V	AC 220 ± 10% 50/60Hz
最大消费电力 Max Power Consumption	KW	0.1
使用气压 Air Pressure	Mpa	0.5 ~ 0.7
空气消费量 Air Consumption	NI/cycle	15.1
驱动方式 Drive System	---	气缸/Air Cylinder
夹具部反转 Chuck twist	---	180°
■ 气缸推力 (气压0.49MPa时) Air Cylinder Driving Force (Air Pressure at 0.49MPa)		
最大可搬重量 Max.Load	Kg	2【含夹具重量 / Incl Chuck Weight】
■ 行程 Stroke		
上下 Vertical	mm	150
前后 Crosswise	mm	650
回转 Swing	mm	50° ~ 90°【0°固定 Fixed】
■ 本体重量 Net Weight		
本体 Main Body	Kg	30

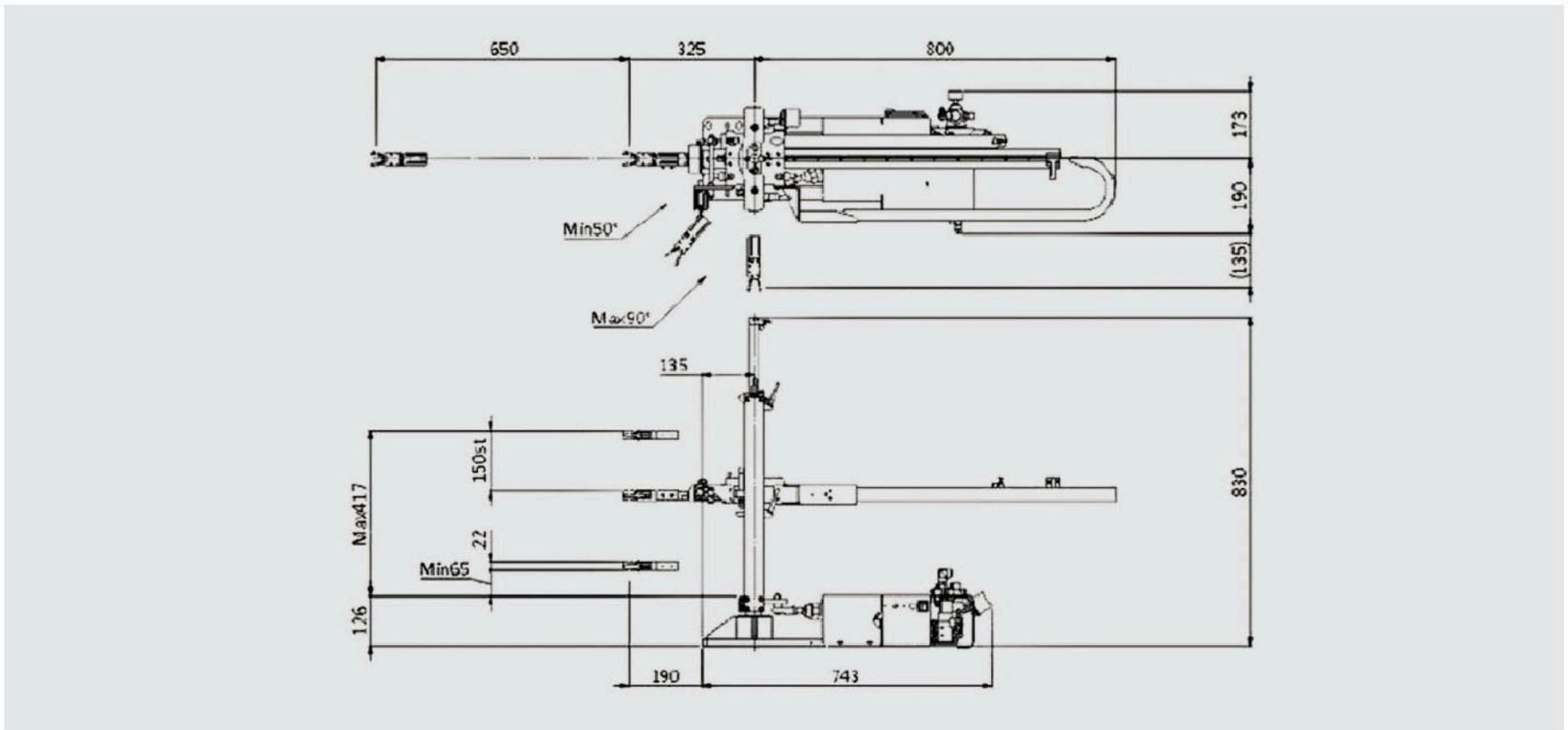

基本动作 MOTION PATTERN Type 1 Type 2

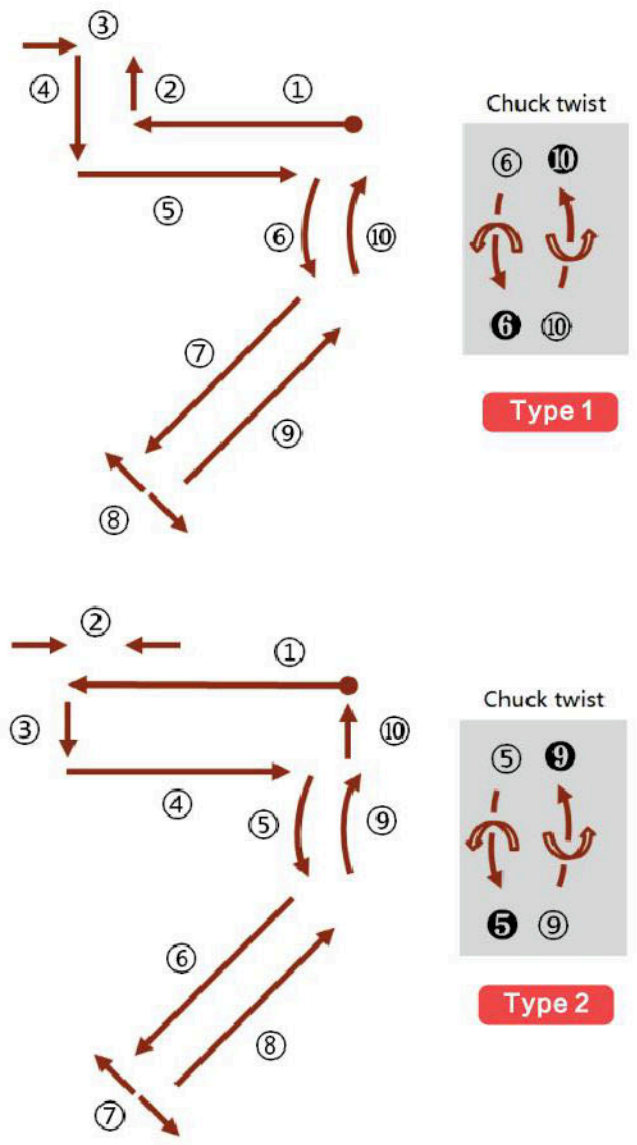

① 前进 Crosswise advance	① 前进 Crosswise advance
② 上升 Ascent	② 产品夹取 Sprue grip
③ 产品夹取 Sprue grip	③ 引拔 Crosswise retreat
④ 引拔 Crosswise retreat	④ 后退 Retreat
⑤ 后退 Retreat	⑤ 回转 Swing action
⑥ 回转 Swing action	⑤ 夹具部反转 Chuck twist
⑥ 夹具部反转 Chuck twist	⑥ 前进 Crosswise advance
⑦ 前进 Crosswise advance	⑦ 产品释放 Sprue release
⑧ 产品释放 Sprue release	⑧ 后退 Retreat
⑨ 后退 Retreat	⑨ 回转复归 Swing return
⑩ 回转复归 Swing return	⑨ 夹具部反转变回 Chuck twist return
⑩ 夹具部反转变回 Chuck twist return	⑩ 待机位置复归 Crosswise advance